



A20/A20U 20~50%RH Dry Cabinet ($\pm 3\%RH$)



▶ Features:

- A20/A20U provides flexible setting range 20~50%RH.
- Gray window frame. It is allow the user to put Bins(optional) for classification and archiving.
- The RS-232 interface allows users to connect the Dual Sensor Data Logger GT-02(Optional) for acquiring the humidity and temperature data of cabinet interior and ambient environment.
- When the sensor runs over 365 days, the Calibration Reminding System(CRS) will remind the user.
- Built-in Flash and Buzzer Alarm will alert the user when the humidity or temperature is higher than the upper limitation.

▶ Applications:

- A20/A20U type is designed to protect the electronic gadgets and valuable collections from moisture damage.



Function of Bins:

- 1.Classification:** Different doors can be classified by project, work sheet, order, client, component, storage life, expiration date or operator etc.
- 2.Retrieving:** Small components are stored in bins inside the parts can be retrieved quickly to avoid opening the doors frequently.
- 3.Archiving:** ISO documents such as work sheet , order, memo or quality instructions etc. can be put in bins outside the door for better QA management.



Bin-G(Optional)

The bins are Not available for A20-157, A20-315 and A20-575.

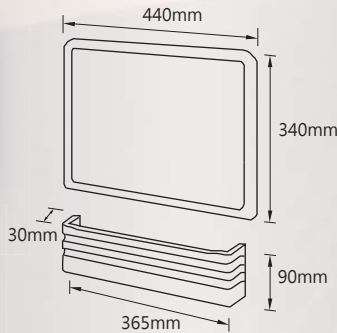

Bins can be installed or replaced within 10 seconds.
Maximum loading of bin: 5kgs



Bin is inside the door.



Bin is outside the door.



A20/A20U 20~50%RH Dry Cabinet ($\pm 3\%RH$)

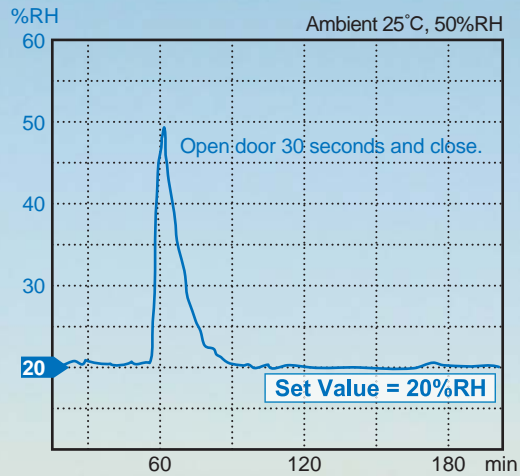

A20-157

Capacity:164L Shelves:3 shelves
 Outside Dimension:W450xD450xH950mm
 Internal Dimension:W448xD422xH870mm
 Power Consumption: Max.140W ; Ave.5Wh



A20-315

Capacity:328L Shelves:3 shelves
 Outside Dimension:W900xD450xH950mm
 Internal Dimension:W898xD422xH870mm
 Power Consumption: Max.140W ; Ave.5.5Wh



A20-575

Capacity:598L Shelves:3 shelves
 Outside Dimension:W900xD800xH1045mm
 Internal Dimension:W898xD772xH870mm
 Power Consumption: Max.140W ; Ave.6Wh

GT04 Data Logger (optional)

Temperature Humidity

Display Panel

Temperature (°C) Humidity (%RH)

Time(h)

1 Ambient Humidity 2 Ambient Temperature
 3 Internal Temperature 4 Internal Humidity



A20U-200

Capacity:200L Shelves:2 shelves
 Outside Dimension:W600xD672xH610mm
 Internal Dimension:W598xD642xH530mm
 Power Consumption: Max.140W ; Ave.5Wh



A20U-400

Capacity:413L Shelves:3 shelves
 Outside Dimension:W600xD672xH1275mm
 Internal Dimension:W598xD642xH1070mm
 Power Consumption: Max.140W ; Ave.5Wh



A20U-600

Capacity:624L Shelves:5 shelves
 Outside Dimension:W600xD672xH1815mm
 Internal Dimension:W598xD642xH1625mm
 Power Consumption: Max.140W ; Ave.5Wh



A20U-1200-6

Capacity:1250L Shelves:5 shelves
 Outside Dimension:W1200xD672xH1815mm
 Internal Dimension:W1198xD642xH1625mm
 Power Consumption: Max.140W ; Ave.9.5Wh

